

# HIGH ACCURACY MANOMETER FOR IN-SITU MEASUREMENTS

Siret, F. and Jardinier, M.

*Aereco S.A., 9 allée du Clos des Charmes, Collégien  
F - 77615 MARNE LA VALLEE Cedex 3*

## ABSTRACT

Our commitment to improve both air quality and energy savings in existing dwellings involves scope measurements campaigns. Constraints linked to the use of measurements material in these conditions, the keeping of their reliability all project long and their costs prompted industry to develop special devices for this kind of application. It is the case of this high accuracy manometer required for the wide demonstration project called HR-VENT (Nangis – France). This monitoring carried out during almost 2 years aims in particular at characterizing the running of a hybrid ventilation system in place of an existing passive stack ventilation system. All in all, more than 160 manometers are installed to measure pressure differences near extract units and gas appliances. Small pressure differences, such as those measured in passive stack ventilation and the required accuracy lead Aereco to design a powerful device with a reasonable cost.

## KEYWORDS

Manometer, high accuracy, measurements, pressure, passive stack ventilation, hybrid ventilation, HR-VENT

## INNOVATIVE PRINCIPLES

Currently, there are a lot of manometers able to measure an absolute pressure or a pressure difference with a high accuracy. However these devices are often very complex and expensive.

Moreover, the hot-wire technology used by this manometer is well known; but usually, to measure air flow speed. It consists of an electrically heated, fine metal wire which is immersed into the airflow; the cooling effect on the wire electrode causing its electrical resistance to change. However, this technology requires frequent calibrations to maintain a high accuracy, especially at low pressures.

Specially designed to run into low pressure ranges (commonly met in passive stack and hybrid ventilation), this manometer aims at releasing these drawbacks.

Next scheme illustrates the theoretical principle of this manometer.

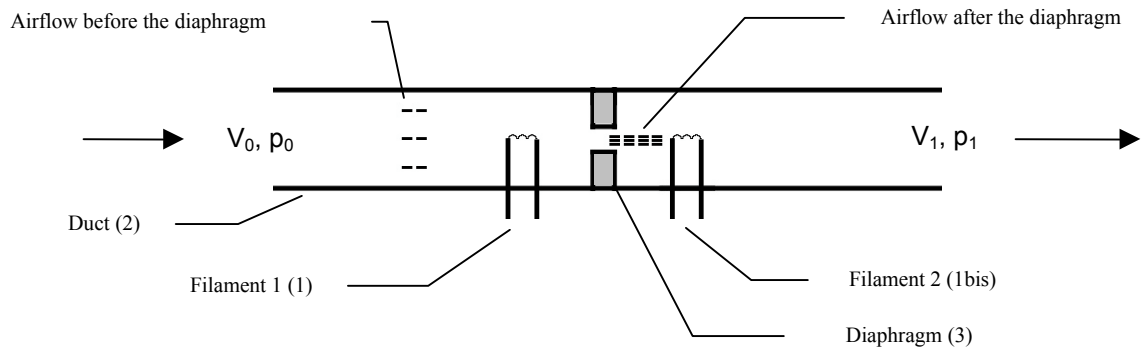

Component and process	Function
Duct (2)	Connection of the volumes $V_0$ and $V_1$
Diaphragm (3)	Canalization and acceleration of the airflow
Voltage Measurements of the 2 filaments at 1 mA	Fixing of the zero point to control drift over time
Voltage Measurements of the 2 filaments at 32 mA	Determination of the flow direction and the pressure difference between the volumes $V_0$ and $V_1$

Figure 1 : theoretical principle

### DESIGN ASPECTS

Concretely, this high accuracy manometer measures the low pressure difference between two air volumes divided by a diaphragm setting out in a duct. When crossed by an airflow, the duct is then subjected to very different fields of speeds here and there of its extremities.

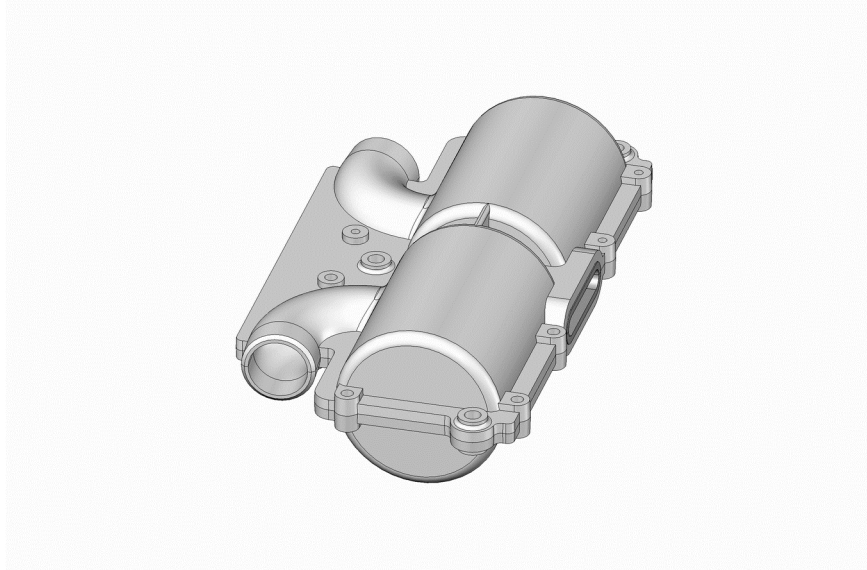

Figure 2 : Enclosure box of the manometer

Next scheme shows constitutive elements of the device and their arrangement

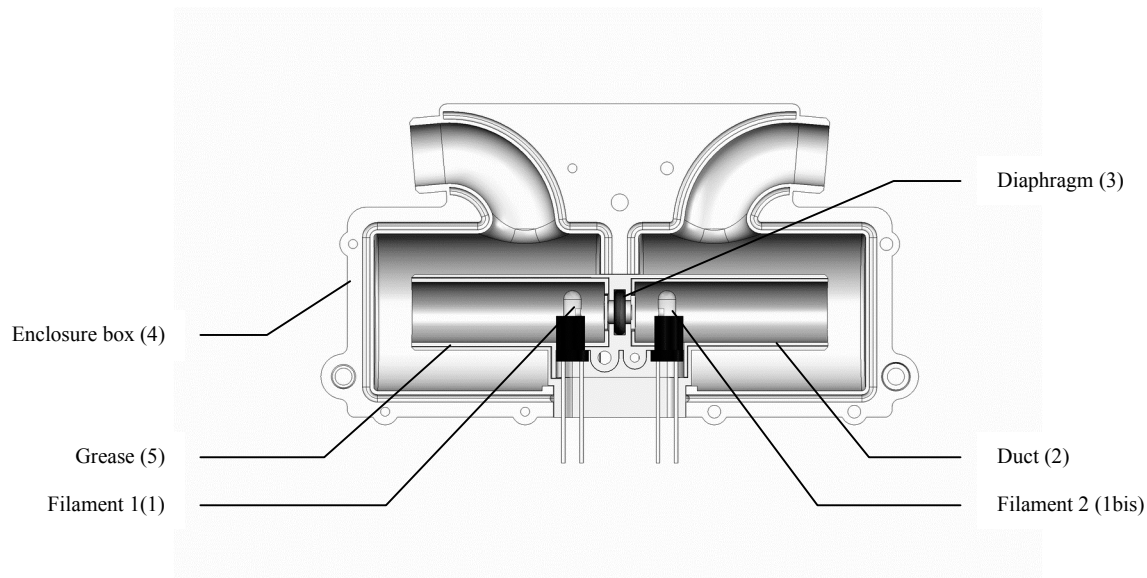

Figure 3 : Cross-section of the manometer

The device shown on figure 3 consists in a duct (2) running in 2 volumes ( $V_0$  and  $V_1$ ) at respective pressure  $P_0$  and  $P_1$ . A cylindrical diaphragm (3) is placed into the duct (2). Here and there this diaphragm (3), the filaments  $F_1$  and  $F_2$  (1 and 1bis), are both placed along the axis of the duct. Made from electrical lamps these hot-wires are powered by a current and their resistance varies with the temperature.

When the air flows from the  $V_0$  volume to the  $V_1$  volume, the diaphragm (3) ensures the canalization and the acceleration of this flow. For example, when the diameter of the diaphragm is the quarter of the diameter of the duct, the air velocity will be sixteen times more important after than before the diaphragm. So, the filament after will be cooled faster than the other. Consequently, the resistances changes of each filament make it possible to show a pressure difference between the two volumes, the direction of the flow and then to determinate the value of the accurate pressure difference. For these reasons, filaments characterized by a big surface of contact and a small inertia are well appropriate to measure such values.

The duct (2) and the filaments  $F_1$  and  $F_2$  are placed in an enclosure box (4) whose inner sides are coated with grease (5). In the same way, the external surface of the duct (2) is coated. This constitutes a filtration of the majority of impurity like dust flowing between the volumes.

## MEASUREMENT PROCESS

Next figure shows the measurement process which leads to the results as accurate as mentioned above.

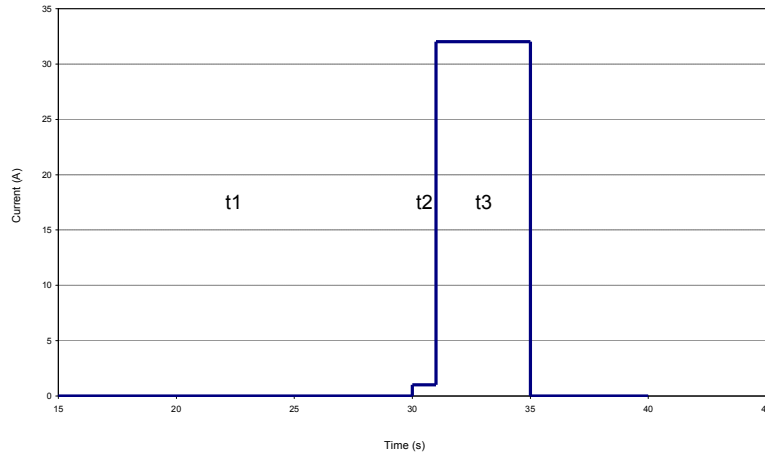

Figure 4 : measurements cycle

During a period  $t_1$ , about 30 to 120 seconds,  $F_1$  and  $F_2$  filaments are not powered.

During a first period  $t_2$ , about 1 second, filaments are powered with a low current (about 1 mA). This first resistance measurement of the  $F_1$  and  $F_2$  filaments is carried out at the ambient temperature and makes it so possible to fix the response. It should be noted that the warm up of the filaments  $F_1$  and  $F_2$  is so low that the cooling effect, caused by the airflow, is completely negligible.

During a second time ( $t_3$ ), long enough to reach the heat balance of the  $F_1$  and  $F_2$  filaments (generally, between and 10 seconds), these hot-wires are powered by an electric current whose intensity is between about 15 and 45 mA. So,  $F_1$  and  $F_2$  hot-wires are heated at a temperature which not have to exceed  $100^\circ\text{C}$ . Then, the new resistances of  $F_1$  and  $F_2$  hot-wires are measured again.

First, airflow has been filtered before; then, the temperature of hot-wires has been increased at a pretty low value. So, thanks to diagrams showing the evolution of the hot-wires resistances as a function of the pressure difference, it is possible to determinate the pressure difference between the  $V_0$  and  $V_1$  environments. At the end, this process can follow an iterative method.

The voltage of the hot-wire is given by :

$$U = I \times R_0 \times (1 - \alpha \times (T_f - T_0))$$

With  $T_f$  : temperature of the hot-wire  
 $(R_0 ; T_0)$  :  $R_0$  is the tungsten filament resistance at a  $T_0$  temperature  
 $\alpha$  : constant of tungsten  
 $I$  = current

With a given  $I$  current :

$$U = f(T)$$

i.e.  $U = f(\Delta p, T_a)$

With  $\Delta p$  : pressure difference

$T_a$  : ambient temperature

Then it is possible to draw 2 pressure calibration curves (negative et positive) showing the response of a filament at 32 mA (cf. Figure 5 : )

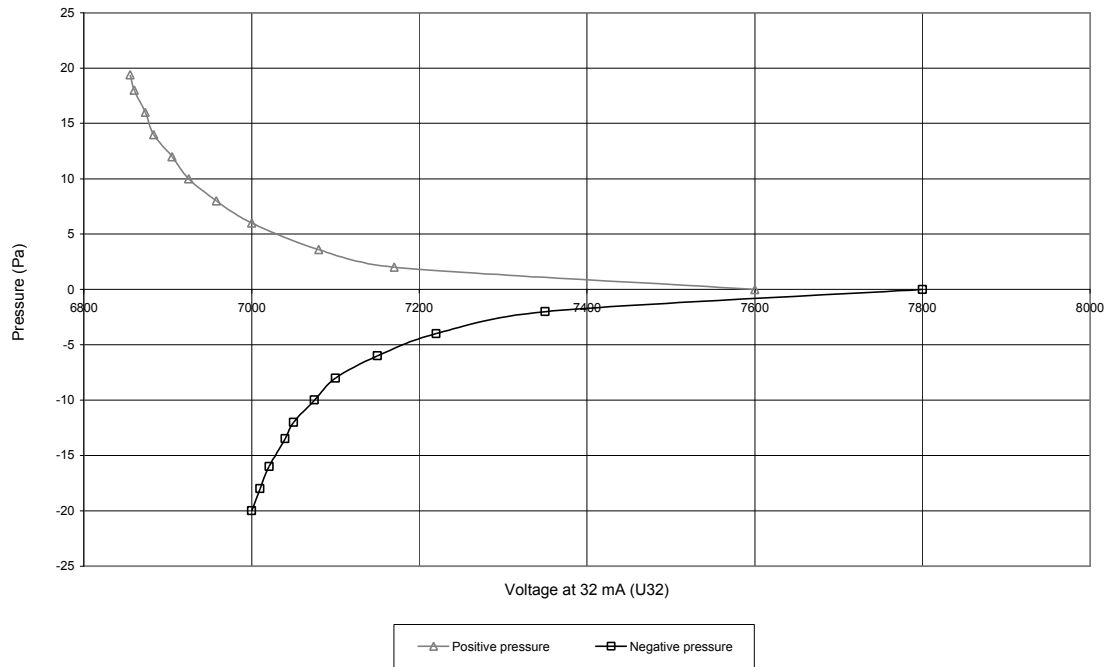

Figure 5 : pressure calibration curves of a manometer



Figure 6 : calibration equipment

Next diagram summarizes the methodological approach which leads to the determination of the pressure difference between two environments.

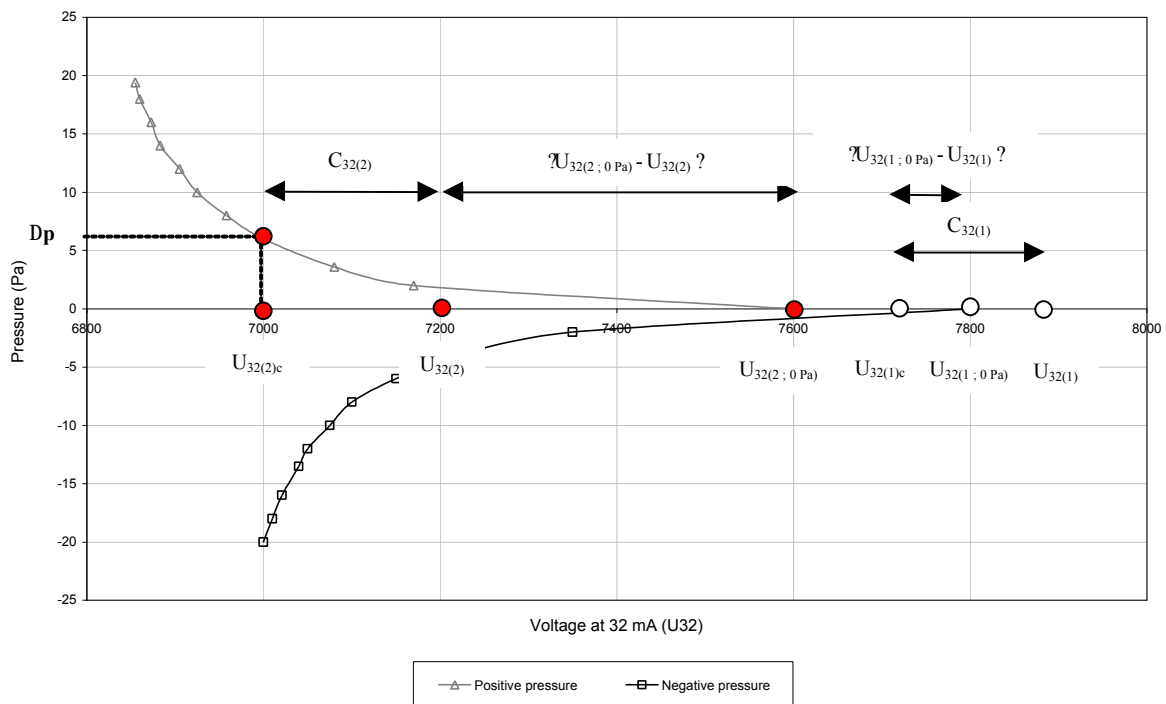
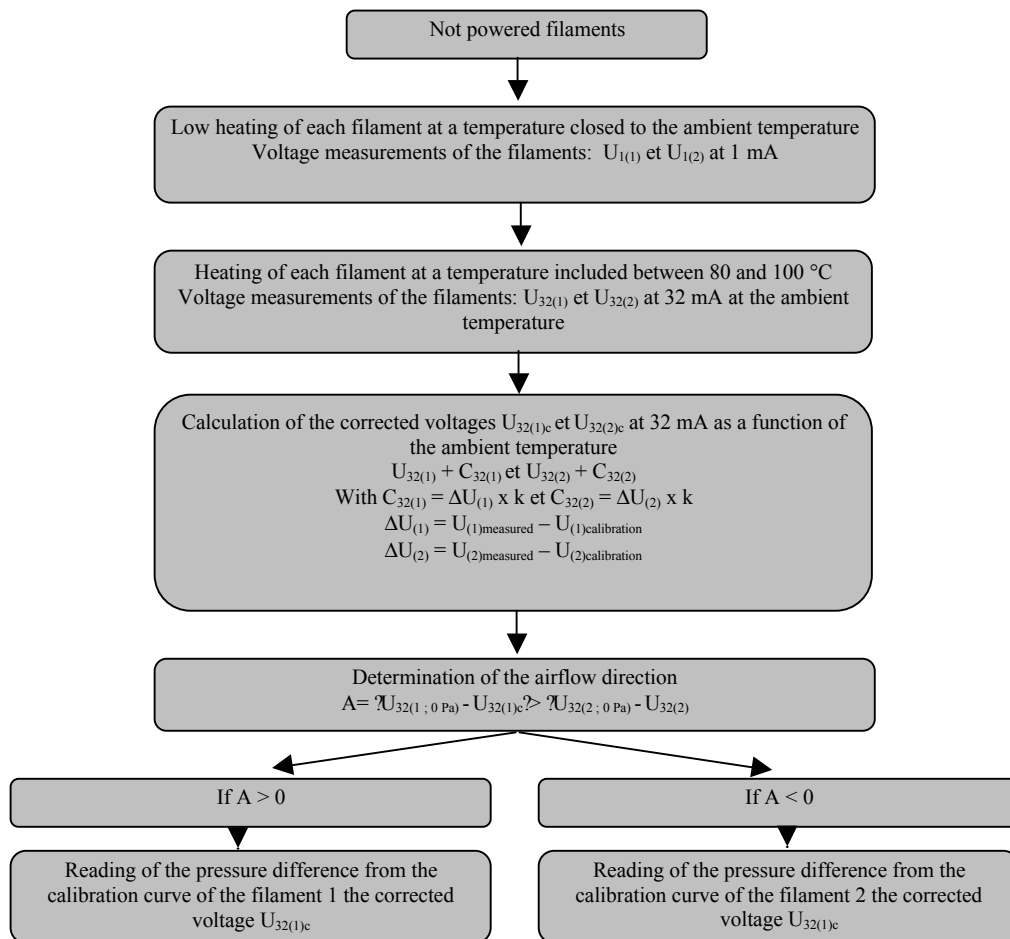

Figure 7 : Graphical method to determinate the pressure difference  $\Delta p$

## APPLICATIONS

Especially designed to measure very low pressure, this patented manometer guarantees an accuracy of about  $\pm 10\%$  between -20 and 20 Pa. Moreover, its manufacturing cost is affordable in comparison with the similar products of the market. This makes it possible to consider a widening of its applications. Its first use took place in HR-VENT, the French Aereco monitoring where about 160 manometers have been installed. Next figure illustrates its simple integration in a box behind a humidity sensitive extract grille for passive stack ventilation.

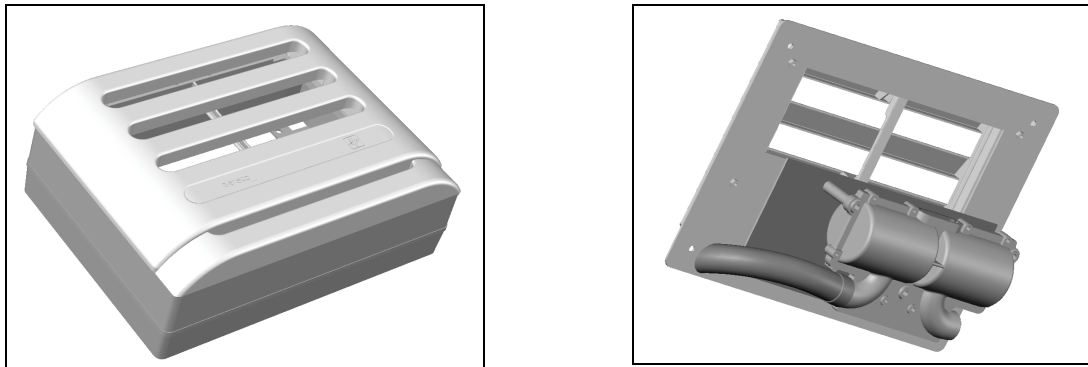

Figure 8 : Humidity sensitive extract grille with high accuracy manometer

Linked to an electronic card of power supply and data acquisition which defines measurements cycles, minute per minute, this manometer shows a true reliability.

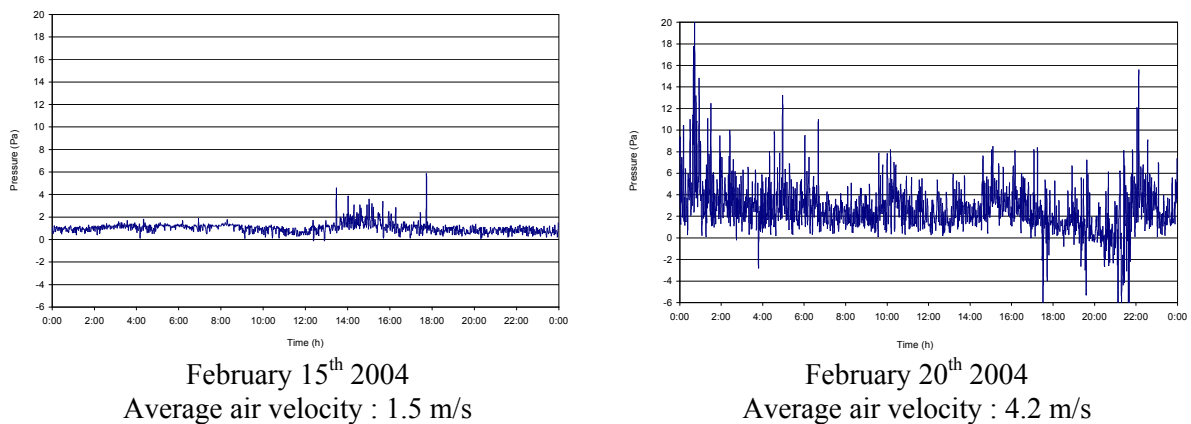

Figure 9 : Comparison between 2 days with different wind conditions

## CONCLUSION

The innovative technology shown before, naturally, leads manufacturer to patent this manometer. Measurements of low pressures with a high accuracy are now possible not only in laboratory but also in-situ. Moreover, the process makes it possible to get results independent from the ambient temperature and with controlled drift over time. With a cost about ten times

cheaper than common products of the market, it is reasonable to believe that this device can extend its application.

## **REFERENCES**

- Siret, F., Savin, J.L., Jardinier, M. and Berthin, S. (2004). " Monitoring on HR-VENT hybrid ventilation project - first results." *25th AIVC conference*.
- Savin, J.L., Jardinier, M. and Siret, F. (2004). "In-situ performances measurement of an innovative hybrid ventilation system in collective social housing retrofitting". *25th AIVC conference*.